

VLEG 5120A LFP Battery System

User Manual

V1.0

Revision Table

No	Version	Revised by	Content	Revision Date
1	Rev1.0		First release	2024.09.02
2				
3				
4				
5				
6				

Content

1 Overview	3
1.1 Application Scope	3
1.2 Applicable People	3
1.3 User Manual	3
1.4 Disclaimers	3
2 Product description	4
3 Safety Instructions	5
3.1 Label Description	5
3.2 Installation Tools	6
3.3 Attention Items	6
3.3.1 Manual Custody	6
3.3.2 Operator Requirements	6
3.3.3 Measuring Instrument	6
4 Product Description	7
4.1 Product Introduction	7
4.2 Module Illustration and Front Panel Description	8
4.3 VLEG 5120A Battery Front Panel Diagram	9
4.4 LED Indicator status and definition	10
4.5 Communication Port Diagram and Description	11
5 Battery Installation	12
5.1 Handling, Transportation, Storage	12
5.1.1 Handling	12
5.1.2 Transportation	12
5.1.3 Storage	12
5.2 Battery Installation Requirement	13
5.2.1 Environment Requirement	13
5.2.2 Open-box Inspection	13
5.2.3 Precautions before installation	14

5.3 Battery Installation	15
5.3.1 Battery Installation and Wiring	15
6 Battery Use	17
6.1 Bluetooth Setting	17
6.2 Supplementary Power	19
6.3 Battery Discharge and End-of-life Judgment	20
6.3.1 Battery Discharge	20
6.3.2 Capacity Test	20
7 Maintenance	21
7.1 Common Faults (Phenomenon) and Solutions	21
7.2 Daily Maintenance	22
8 Cautions and Warranty	23
8.1 Cautions	23
8.2 Description of Warranty	23

1 Overview

1.1 Application Scope

This manual introduces the information about VLEG 5120A LFP battery product, including product specifications, operation specifications, product maintenance and other related information. These LFP battery products are developed by Voltgo power, have been widely used in many scenarios, such as toy car, medical cart, E-boat E-golf etc.

1.2 Applicable People

This manual is used for professional and technical staff who installs, operates and maintains the batteries, as well as for the end-user who may need to view the relevant technical parameters. Anyone who operates must be qualified for electrical work.

1.3 User Manual

Before you operate the battery module, you should be better trained and read the manual carefully, to ensure that the person using the product is fully understood. Remove any possible metallic shorting risk of Jewel, Watches, Pens. Metal bars and frames. After reading, please keep it in a safe place for future reference.

1.4 Disclaimers

It may cause serious injury to yourself or others, or result in damage to the product or property, if fail to operate this product properly. Once using, you will be deemed to have understood, acknowledged and accepted all the terms and contents in this document. Users undertake to be responsible for their own actions and all the consequences arising therefrom. The company shall not be liable for all damages caused by the user's failure in accordance with the provisions of this document and the user manual.

The content of this manual will be constantly updated and revised, and update, revision or termination without prior notice. So please visit the our official website or obtain the latest product manual through your local distributors.

2 Product description

Lithium-ion batteries are a new generation of green energy batteries. In recent years, with the rapid development of lithium ion battery technology, the pace of lithium ion batteries to replace the traditional lead-acid batteries are also gradually accelerate in various power fields.

Voltgo power develops and produces VLEG 5120A LFP battery product, which are suitable for low-voltage lead-acid replacement applications. These products adopt the highest safety performance lithium iron phosphate cells, with a high-precision battery management system (BMS), which can monitor and collect voltage, current and temperature of each cell in the module in real time. The BMS also has a passive balance function, advanced battery control strategy, which can improve the performance of the battery pack further.

VLEG 5120A battery products consists of LFP battery module, BMS/BMU, housing and wire. Each module owns complete protection function. The modules can be connected in parallel to meet the expansion needs.









VLEG 5120A lithium iron phosphate(LFP) battery module is specially designed for golf cart by Voltgo. This battery module adopts an ABS shell which can be used 24/7. It has outstanding advantages of being waterproof, Bluetooth capabilities, heating features, impact resistance, good insulation performance, easy installation and maintenance-free. Battery module integrates intelligent BMS, which offer great advantages in terms of safety, cycle life, balancing and smart control.

3 Safety Instructions

3.1 Label Description









In order to ensure the user's personal safety when using this product, this manual provides relevant identification information and uses appropriate symbols to alert the user, who should carefully read the following list of symbols used in this manual.

Table 3-1 Label description

	Potentially low risk: may result in mild or moderate impairment if not avoided
	High Risk: May result in serious injury or death if not avoided
	The battery terminals must be disconnected before commencing on the battery
	The battery could explode and/or be severely damaged if dropped or crushed
	The battery may explode if exposed to open flames or other extreme sources of heat
	This side should be up
	Handle with care to avoid damage
	Keep dry
	Keep the battery away from kids
	Do not short circuit
	Do not reverse connection the positive and negative

3.2 Installation Tools

Table 3-2 Installation tool sheet

Tools	Multi-meter 	Protective gloves 	Insulated anti-smashing shoes 
	Electric screwdriver 	Cross screwdriver 	Socket spanner 
Installation Tools	Slotted screwdriver 	Wire stripper 	

3.3 Attention Items

3.3.1 Manual Custody

This manual contains important information about the VLEG 5120A battery. A careful reading of this manual will help you become familiar with this product, and this manual should be kept in a safe place so that it can be easily accessed by maintenance personnel at any time when needed.

3.3.2 Operator Requirements

 Only trained and qualified professionals should perform various operations on the product: the product operator should be fully familiar with the product's system components and operating principles, as well as understanding the product's user manual.

3.3.3 Measuring Instrument

 In order to ensure that the electrical installation meets the requirements, please use the relevant electrical measuring equipment, such as multi-meter, power meters, etc.

4 Product Description

4.1 Product Introduction

VLEG 5120A LFP battery adopts the highest safety performance lithium iron phosphate battery. Each battery module has a built-in full-featured & high-precision battery management system (BMS), which can realize real-time monitoring of voltage, current and temperature, and has a passive balance function, which can effectively improve the battery performance.

Meanwhile VLEG 5120A battery own special structure design, the metal strips can be used not only as a handle, but also as a "floor lock" & "rear lock", and as a connecting strip when multiple batteries are used in combination, which can greatly improve installation efficiency and reduce special tools requirement, that will obviously extend the battery application fields. And unique safety design (cell, structure, bracket, aerosol automatic fire extinguishing device) can greatly improve the safety performance of the battery.

Table 4-1: VLEG 5120A battery specification

Type	Voltage [V]	Capacity [Ah]	Energy [Wh]	Width [mm]	Depth [mm]	Height [mm]	Weight [kg]
VLEG 5120A	51.2	100	5120	460	320	247	43

4.2 Module Illustration and Front Panel Description

Figure 4-1: VLEG 5120A Appearance drawing

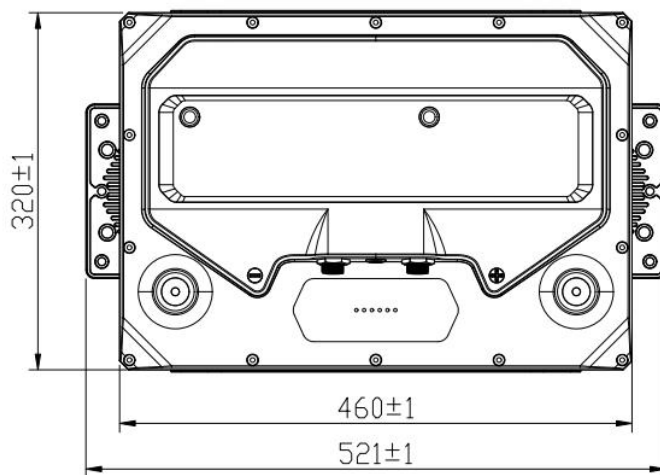
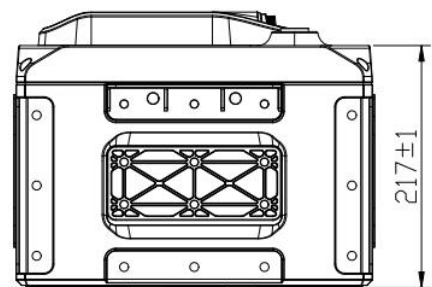
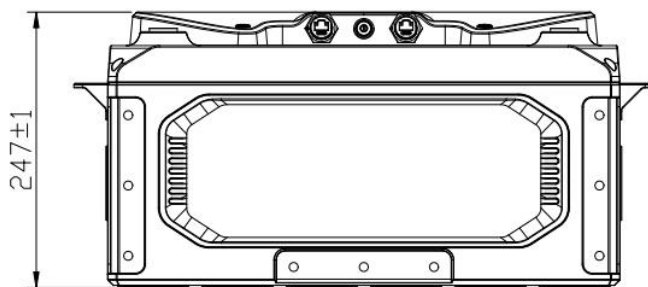

4.3 VLEG 5120A Battery Front Panel Diagram

Figure 4-2: VLEG 5120A Battery Front Panel

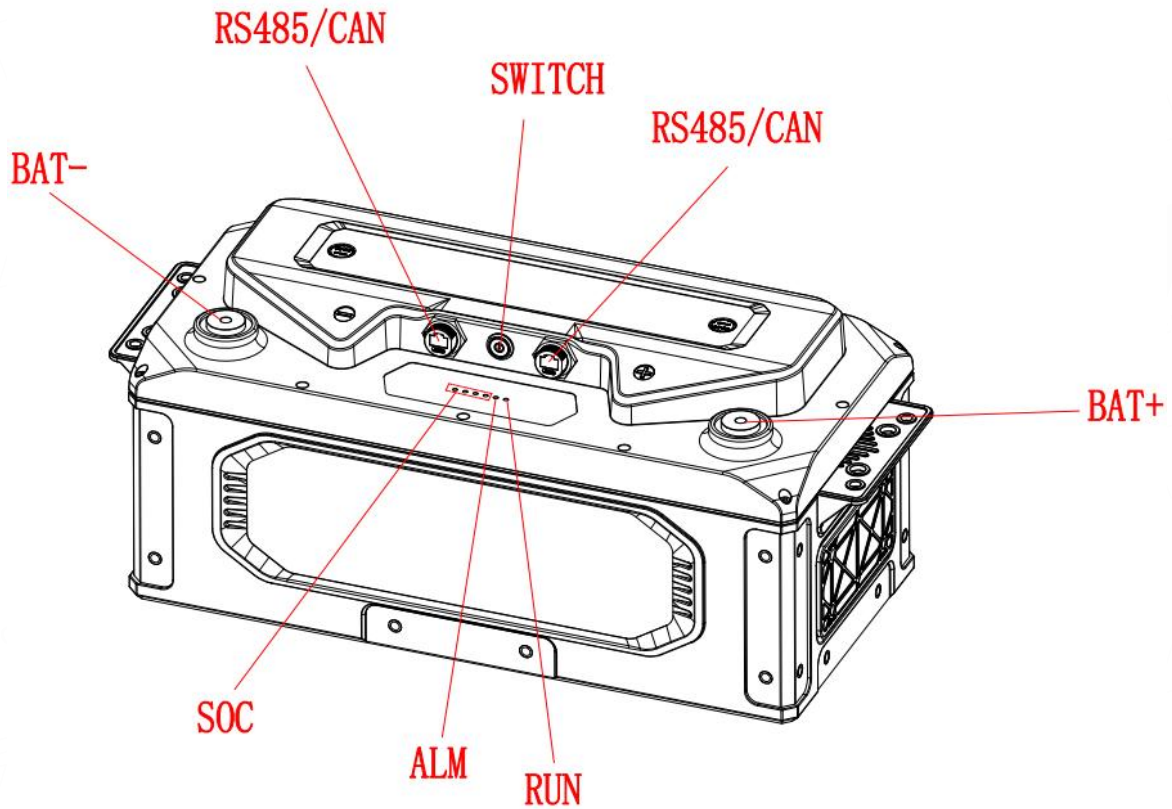

Table 4-1 VLEG 5120A battery front panel interface description

No.	Item	Function Description	Remarks
1	BAT+	Positive terminal	M8 Screw
2	RS485/CAN	Communication port	
3	Switch	Button Switch on/off the BMS	
4	BAT-	Negative terminal	M8 Screw
5	ALM	Alarming indicates LED	
6	RUN	Operating indicates LED	
7	SOC	The state of charge	4 nos green LED

4.4 LED Indicator status and definition

Table 4-2 LED indicator status and definition

Status	Normal/Alarm/ Protection	RUN	ALM	SOC Indicate LED	Notes
		●	●	SOC1~SOC4●	
Shutdown / Sleep		OFF	OFF	OFF	
Stand by	Normal	ON	OFF	Based on SOC indicator (Each LED indicators 25%SOC)	According to the state before standby
	Alarm	OFF	ON		
Charge	Normal	Long Flash	OFF	Based on SOC indicator	Long Flash: OFF: 1.0S/ON: 1.0S
	Alarm	OFF	ON		
	End-off Voltage	ON	OFF	ALL ON	
	Over-Temp Protection	OFF	ON	Based on SOC indicator	
	Over-current transfer limit -current	Long Flash	OFF		
Discharge	Normal	Short flash	OFF	Based on SOC indicator	Short Flash: OFF: 0.5S/ON: 0.5S
	Alarm	OFF	ON		
	End-off Voltage	OFF	ON	ALL OFF	Go to sleep
	Over-Temp/Over-c urrent Protection	OFF	ON	Based on SOC indicator	
BMS Fault	OFF	ON			

4. 5 Communication Port Diagram and Description

Figure 4-3 Communication interface diagram

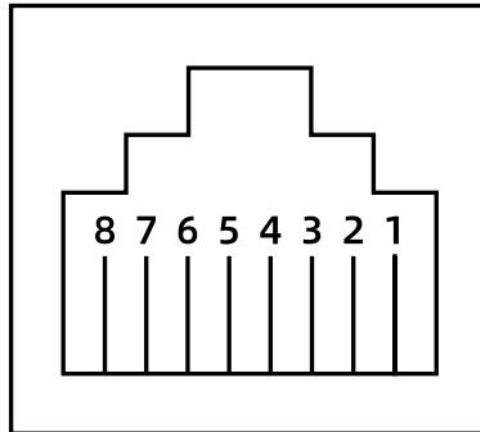

Table 4-3 Communication interface definition

COM1	Definition	COM2	Definition
Pin 1	CAN-H	Pin 1	CAN-H
Pin 2	CAN-L	Pin 2	CAN-L
Pin 3	GND	Pin 3	GND
Pin 4	LIN	Pin 4	LIN
Pin 5	WARK	Pin 5	WARK
Pin 6	Vcc-12V	Pin 6	Vcc-12V
Pin 7	RS485-A	Pin 7	RS485-A
Pin8	RS485-B	Pin8	RS485-B

5 Battery Installation

5.1 Handling, Transportation, Storage

5.1.1 Handling

Rough handling practices may cause short circuit or damage to the battery pack, resulting in battery leakage or fire.

 Forklifts or carts should be used for handling.

 Materials transported should not exceed the width and height of aisles and doors, and should be transported at a moderate speed.

 Avoid the phenomenon of inverted and laminated battery packs when unloading.

 Avoid touch the terminals when handling the battery.

 Avoid battery short-circuit when handling the battery.

5.1.2 Transportation

 Due to the heavy weight of the battery module, in order to guarantee safety, a forklift or multi-person handling is recommended

 Avoid dropping and throwing; the equipment should be prevented from collision and strong vibration during transportation.

5.1.3 Storage

 Short-term storage (within 3 months): If the battery is not used in a short period of time, the battery can be fully charged and stored in a dry, cool, non-corrosive gas, temperature 10-45°C, relative humidity 60±30%, no strong electromagnetic fields and in direct sunlight.

 Long-term storage (over 3 months): If the battery is not used for more than 3 months, keep the battery SOC at 50%~70%, store it in a dry, cool, non-corrosive gas, temperature 20-35 °C, relative humidity 50 ± 15 %, in an environment without strong electromagnetic fields and direct sunlight, and make sure to charge once every 6 months to avoid irreversible capacity loss caused by long-term storage.

5.2 Battery Installation Requirement





5.2.1 Environment Requirement

Table 5-1: Environment requirement

Application scenarios	E-golf, E-boat
Operating Environment	All-weather
Discharge Temperature (°C)	-20~55
Storage Temperature(°C)	10-45
Humidity(%)	5 ~ 95% RH

5.2.2 Open-box Inspection

Table 5-2: Unpacking tools sheet

Item	Tools			
Tools	Slotted screwdriver 	Protective gloves 	Stripper 	Hammer 

VLEG 5120A products have been strictly tested and tested before leaving the factory. Please sign for them after inspection. If the product is damaged, please contact the local distributor in time. Please open the box to check: whether the outer packaging is intact or damaged; whether the quantity and type of goods on the bill of materials are consistent with the description; whether the internal equipment is damaged.

5.2.3 Precautions before installation







-  Make sure every battery modules should be fully charged when used in groups.
-  Avoid moving the position or touch the contact terminals after installation unless necessary.
-  Avoid installing the battery near a heat source (such as a transformer).
-  Make sure the terminals show normal metallic luster before connecting, if the luster is dull or there are obvious traces of rust, polish the terminals with sandpaper.
-  Avoid metal conductors touching the positive and negative terminals of the battery
-  Use correct tools and appropriate method to avoid damage to the terminal, the recommended tightening torque is shown in the table.

Table 5-3: Torque parameter sheet

No.	Scope of application	Tightening torque value
1	M6	8.5N*m
2	M8	12.4N*m

5.3 Battery Installation

5.3.1 Battery Installation and Wiring

- ①. Place the battery on a flat floor or shelf;
- ②. Remove the "handle" on the casing, the metal part can be turned into a "ground lock", and the battery can be fixed on the floor with an electric drill; if the metal part is placed on the side of the battery, it can be turned into a "back lock", use an electric drill can attach the battery to the wall, as shown in 5-1;

Figure 5-1: Installation Drawing



- ③. When multiple batteries are used in parallel, the rectangular metal strip can be used as a connecting plate, and an electric wrench is used to connect the batteries together, as shown in 5-2;

Figure 5-2: Battery Installation Drawing

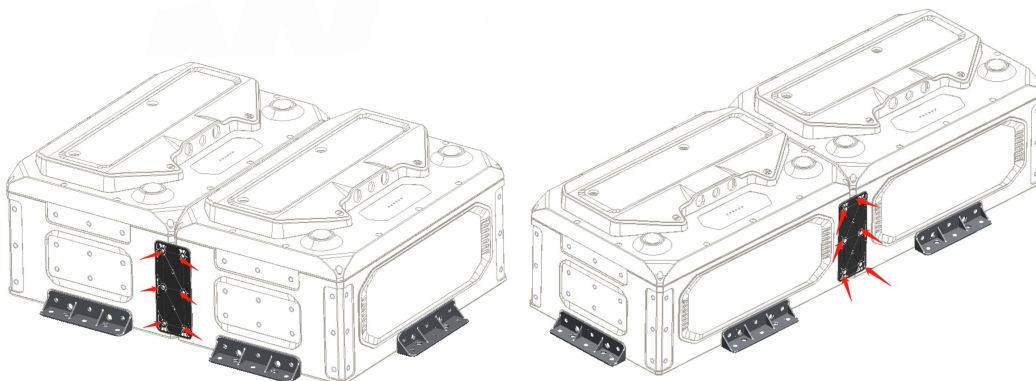

④. Connect the communication port in a daisy chain sequence using communication network cable, as shown in 5-3;

Figure 5-3: Battery Communication Cable Connection Diagram

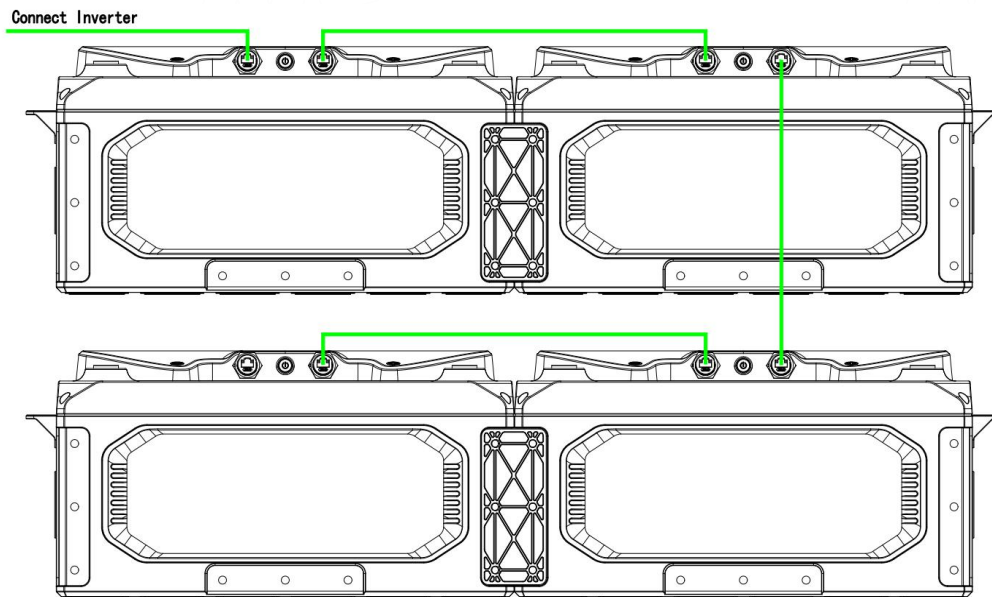

⑤. Parallel connect the power cable, as shown in 5-4;

Figure 5-4: Battery Power Cable Connection Diagram

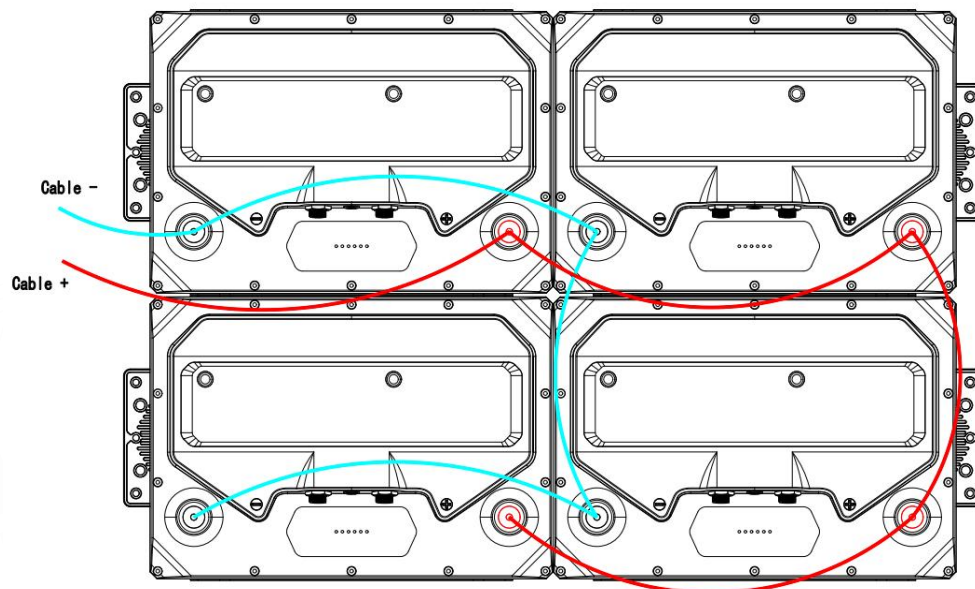

Tips:

- 1) Ensure that the battery capacity are same before use.
- 2) VLEG 5120A battery can't support series connection. Please pay attention to the wiring method.

6 Battery Use

If the battery needs to communicate with the inverter, the battery address and protocol need to be set through Bluetooth. If used as a lead-acid battery, it can be directly connected in parallel without action.

6.1 Bluetooth Setting

①. Download BatteryMonitorBL APP. Search for BatteryMonitor on the APP Store using phone, and download it, as shown in 6-1.

Figure 6-1: APP Store search



- ②. Open the BatteryMonitorBL App and press OFF/ON switch of battery.
- ③. Connect battery and BatteryMonitorBL APP by Bluetooth. Search for batteries and connect it according to the Bluetooth label of battery, then click "Connect". It will display battery information, as shown in 6-2.

Figure 6-2: APP connection

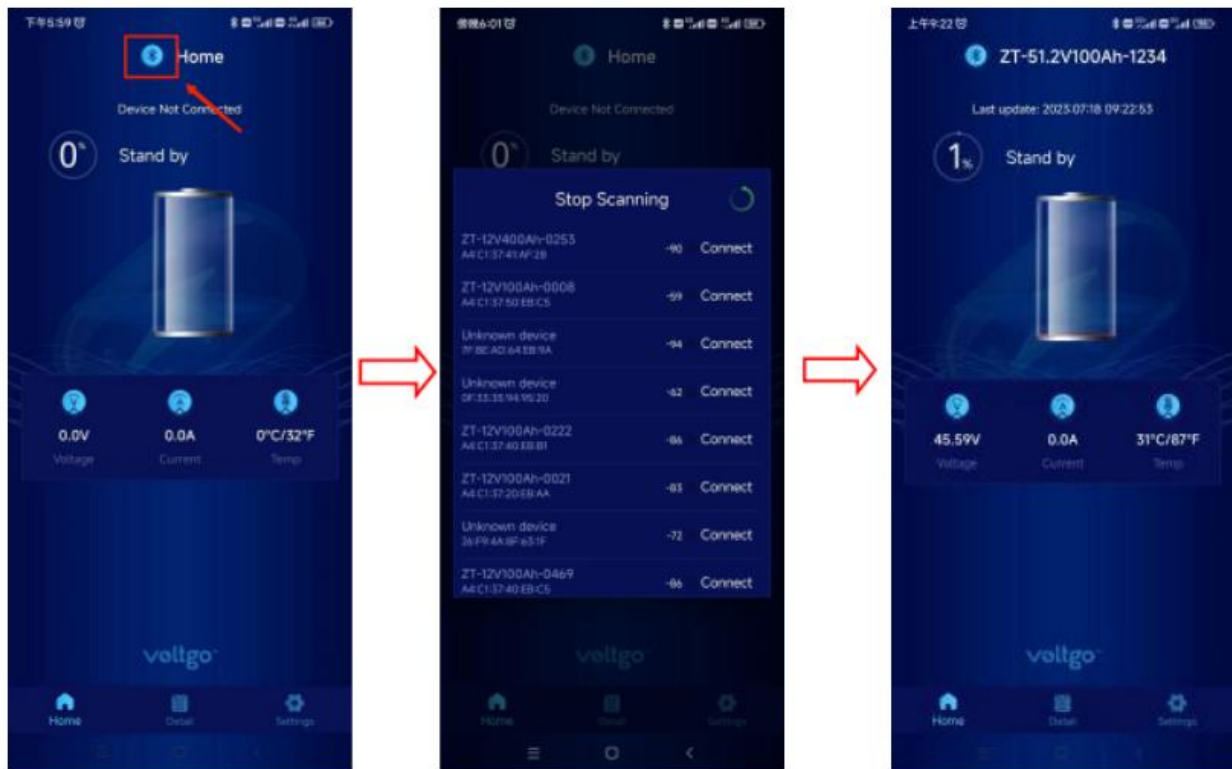

- ④. Select ID address. Enter the settings interface, click on "Module ID", select the appropriate ID (defaults=16). Restart the battery after changed, as shown in 6-3.

If the batteries are connected in parallel, set battery ID1, 2, 3, ..., ID16 according to the number of parallel connections. ID1 is the host and can be connected to the CAN display screen to display battery information.

Figure 6-3: Module ID selection

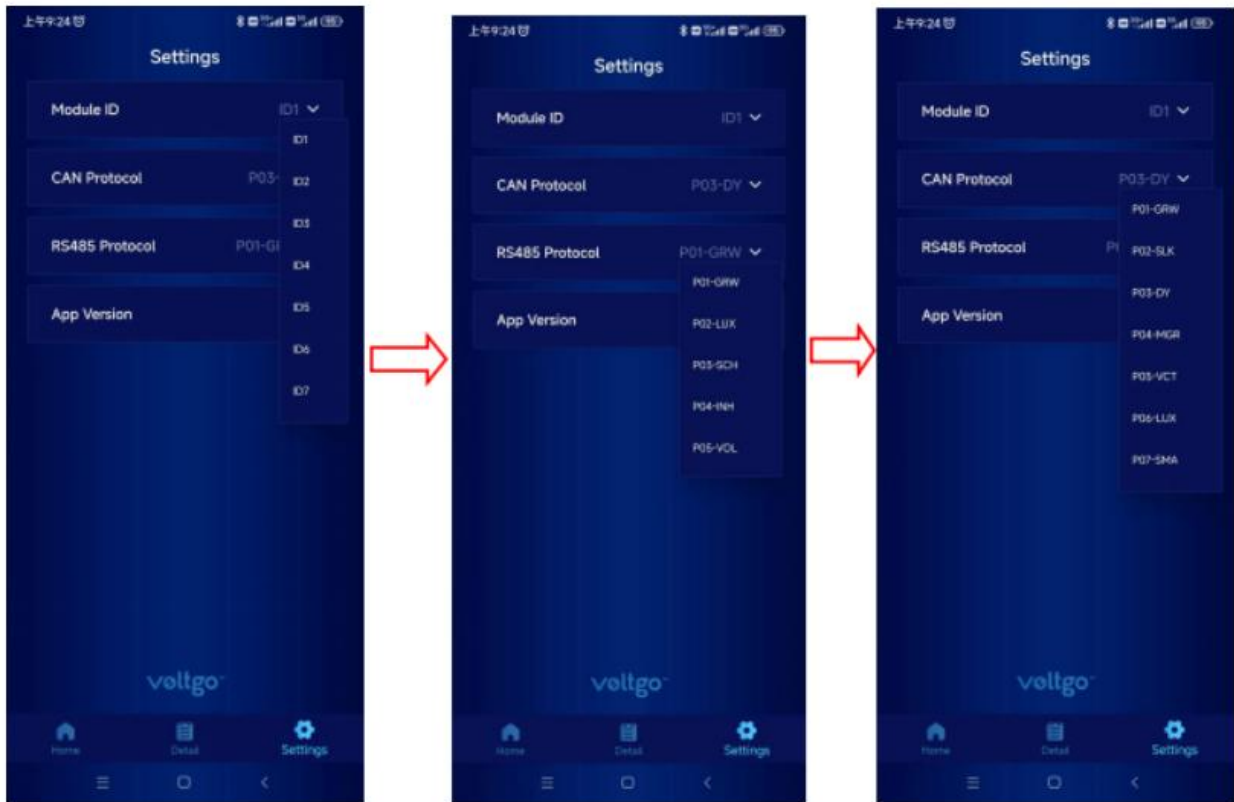

6.2 Supplementary Power

- ①. During transportation and storage, the battery itself will lose part of power. It is recommended to fully charge the battery before use.
- ②. If stop using within a certain period of time, it needs to be replenished regularly.
- ③. The time interval and method of replenishment are shown in the following table

Table 6-1: Battery storage temperature and time interval for recharging

Storage Temp	Refill interval	Charging method	Remarks
≤20°C	Once/9M	56V30A CC/CV Charging to 56V, cut-off current: 5A	Only for 51.2V module
20°C~30°C	Once/6M	56V30A CC/CV Charging to 56V, cut-off current: 5A	
30°C~40°C	Once/3M	56V30A CC/CV Charging to 56V, cut-off current: 5A	

6.3 Battery Discharge and End-of-life Judgment

6.3.1 Battery Discharge

The BMS will automatically cut-off while the battery reaches to lower-limit voltage without human intervention. Do not continue to hang the load on the battery to avoid the over-discharge phenomenon after the battery discharge termination.

6.3.2 Capacity Test

According to the standard capacity calibration method defined in the battery specification, charged and discharged the battery, and after three cycles, the last capacity is the actual capacity. If the test temperature and test conditions are different, the capacity value may fluctuate to a certain extent.

7 Maintenance

7.1 Common Faults (Phenomenon) and Solutions

Common faults and solutions are shown in table 7-1.



Table 7-1 Common faults(phenomenon) and solutions

NO.	Fault phenomenon	Analysis	Solution
1	No DC output	Not press switch or low voltage	Press switch or charge the battery
2	Power supply time is too short	Battery capacity lack or not full power	Maintenance or replacement
3	Battery can't be charged fully	Power system DC output voltage falls below the minimum charge voltage	Regulating DC output voltage of power supply to battery suitable charging voltage
4	ALM LED always lights	Power line connection short circuit	Disconnect the power cable and check all cables
5	The battery output voltage is unstable	Battery management system do not operate normally	Press the switch to restart the battery
6	The charge and discharge capacity is insufficient	Unbalance voltage with cell	Examine/balance the cell
7	Unable to charge and discharge	BMS or cell/temperature sensor damaged	Maintenance or replacement
8	Different SOC value of batteries in parallel	Normal phenomenon	No operation

7.2 Daily Maintenance

Routine maintenance items are shown in Table 7-2 below.

Table 7-2 Routine maintenance items

Item	Maintenance Method	Maintenance intervals
Power Cables 	<ol style="list-style-type: none"> 1. check whether there is mechanical damage to the power cable and whether the terminal insulation sleeve has fallen off; if there is such a phenomenon, please turn off the machine and carry out maintenance or replacement. 2. check whether the power cable is loose; if there is any sign of looseness, please use a standard torque wrench to tighten it. 3. check the system for loose screws or discoloration of the copper bus bar; if the screws are loose, please tighten them with a standard torque wrench; if the copper bus bar is discolored, please contact the manufacturer for after-sales replacement. 	Once every 6 month
Communication Cables 	<ol style="list-style-type: none"> 1. check whether the parallel communication cable terminal is loose, if it is loose, re-tighten it. 2. check whether the color of the communication cable has obvious discoloration, if discoloration, please shut down the machine to replace the communication cable 	Once a year
Cabinet Cleanliness	Check the cleanliness of the front door, back door and battery module inside the cabinet, if there is obvious dusty, please clean up in time.	Once 6-12 month
System running status 	<ol style="list-style-type: none"> 1. check if all parameters are normal when the system is running (system voltage, current, temperature, etc.) 2. check whether the main core components of the system are normal, including system switches, contactors, etc. are normal 3. check whether the system air inlet and outlet, air ducts are normal, if there is blockage and congestion, need to clean up in time 	Once every 6 month
Charge and discharge maintenance	Use light load and shallow charge/discharge to check whether the SOC, SOH status of the battery is normal (using the upper computer software to read); it is recommended that the depth of discharge and charge/discharge power should not exceed 20% of the rated value	Once every 6 month

8 Cautions and Warranty

8.1 Cautions



Please read and comply with the following conditions of installation and use of the battery, incorrect installation using the battery may cause personal injury or damage to the product.

- (1) DO NOT throw the battery into water. Store batteries in cool and dry environment.
- (2) DO NOT put the battery into fire or heat the battery, so as to avoid explosion or other dangerous events.
- (3) When charge the battery, please choose specialized charging equipment, and follow the correct procedures, do not use unqualified chargers.
- (4) DO NOT reverse positive and negative terminals, do not connect the battery directly to AC power, avoid battery short circuit.
- (5) DO NOT using batteries from different manufacturers or different kinds, types together, and do not mix old batteries and new batteries.
- (6) DO NOT use the battery when it is hot, bulges, deforms or leaks.
- (7) DO NOT puncture the battery by nail or other sharp objects; Do not throw, stamp on, impact or hit the battery.
- (8) DO NOT open or try to repair the battery when it is defective. Warranty invalid if the battery repaired or disassembled.
- (9) Batteries are half charged before shipment, Don't use the battery if it's hot, bulge, or smell abnormal and so on, and report to after-sale dept. immediately.
- (10) If you need storage the battery for a long time, please charge and discharge the battery every three months to ensure the best performance, and the best state of charge for storage is between 50%~60%.
- (11) Please use the battery in the temperature range which defined in the manual.
- (12) The state of charge of batteries is 50% before shipment, please charge the battery before using.

8.2 Description of Warranty

We promises that during the valid warranty period of the product, any problems such as product damage or functional failure caused by non-human or intentional damage will enjoy our free repair and replacement services. Customers need to provide a valid purchase invoice or related product warranty information. If no valid proof can be provided, our company has the right to refuse to provide related services.